



Reliability Comparison of Five 220 KV Substations in Pakistan Power System

Adeel Khan, Muhammad Iftikhar Khan, Mubasher Hussain

Abstract— In modern electrical power system, the reliability is considered to be an important factor in power system operation. The term reliability defines as the ability of power system to deliver an adequate supply of electrical energy to the consumers. Fault tree analysis and event tree analysis are the two methods used here for reliability analysis. To find the failure probability fault tree is used. To classify whether the system is safe or not event tree is used. The reliability of five 220kV National Transmission and Dispatch Company (NTDC) substations of Pakistan with respect to protection failures evaluates in this paper. The main method used in this study is Event Tree Analysis. Fault tree analysis helps to find the input for event tree.

Keywords—National Transmission and Dispatch Company, Event tree analysis, Fault tree analysis.

1. INTRODUCTION

In electrical power system, the grid substation is the strongest point, it still contains a chance of loss of load due to weak point in the system. Therefore, it is important to determine the substation reliability as it helps to find the point of failure that may be causing unreliability to whole system.

The three factors on which the substation reliability mainly depends that leads to protection failure are: incorrect system design, incorrect component installation and deterioration of service [1]. To evaluate the reliability of substation different techniques and computational simulations are used. Substation connectivity is mainly focused in most of the studies. Protection system reaction is fully neglected. In substation arrangements to select the failure modes and in outage categories, minimum cut set techniques are used.

Event tree analysis (ETA) [2, 3], fault tree analysis (FTA) [2, 3], state enumeration and Monte Carlo simulation [4, 5] are

the methods that are mostly used. Which technique is to be used varies on the method of evaluation. FTA, state enumeration and Monte Carlo simulation used to study the static reliability. ETA and sequential Monte Carlo methods are used for dynamic reliability.

Design and connection faults are neglected in this paper and only considered criteria is the service deterioration. Protection system failures and failures of associated circuit breaker (CB) are the two types of failures of protection that are considered in this study. FTA is combined with ETA in this study. The method used in this study is ETA and to get the event tree input FTA output is used [6, 7].

2. METHODOLOGY

To minimize the quantity of elements in event trees, components are combined into one unit that are in the similar protection zone. The protection scheme will respond if any element in a zone fails. Consequently, to evaluate this “unit” unavailability FTA is required. The result for the ETA will be the probability of initiating event.

Based on the back up protection, primary protection, and CBs functionality ETA has four states [8].

State 1: There will be no failure of protection if the circuit breakers and primary protection both function well and successfully it will clear the fault.

State 2: If the fault sense by the primary protection but associated CBs fails to respond, it will have energized the failure function of the CB. The circuit breaker failure function will trip the associated CBs.

State 3: If primary protection fails to detect the fault, after some time delay the fault will be cleared by the back-up protection.

State 4: The chance of failure of both the back-up protection and primary protection are not considered. The back-up CBs in this paper are supposed to be perfect.

The probability can be simply calculated of event trees with probabilities products along the tree branch, if the events are independent of each other. Thus, by multiplying the tree branch's probability of each event, the event tree of four states probability can be evaluated,

Adeel Khan: Research Scholar at University of Engineering and Technology, Peshawar, Pakistan. Email: adeel_khan182@yahoo.com Cell: 0092-3347354535.

Muhammad Iftikhar Khan: Associate Professor at University of Engineering and Technology, Peshawar, Pakistan. Email: miftikhar74@gmail.com Cell: 0092-333-9181101.

Mubasher Hussain: Research Scholar at University of Engineering and Technology, Peshawar, Pakistan. Email: mubasher_hussain921@yahoo.com Cell: 0092-3455606120.

$$P(\text{State. 1}) = \frac{U_{av}(\text{ini}) \times \text{Ava}(\text{pri}) \times \text{Ava}(\text{CB})}{\text{Ava}(\text{CB})} \quad (1)$$

where $U_{av}(\text{ini})$ represents the initial event unavailability, $\text{Ava}(\text{pri})$ represents the primary protection availability and $\text{Ava}(\text{CB})$ represents the circuit breaker availability.

If the initiating event input data changed to failure frequency from its unavailability while keeping the protection failure and CB failure conditional probabilities, it will also change the tree output to a failure frequency,

$$P(\text{State. 1}) = \text{fre}(\text{ini}) \times \text{Ava}(\text{pri}) \times \text{Ava}(\text{CB}) \quad (2)$$

where $\text{fre}(\text{ini})$ represents the initial event failure frequency. The probability of failure and unavailability concept pairs are comparatively the similar. Availability/unavailability are the used parameters in this paper.

Before analyzing substation reliability, first made several assumptions.

- Components that are connected to the substations such as isolators, circuit breakers, bus bar, step-up transformers, step-down transformers, potential transformers, current transformers, cables and overhead lines are having a chance to failure.
- Substation reliability does not effect by surge arrestors and earthing switches within substation so they are ignored.
- Assumed that back-up circuit breakers system and the systems back-up protection are to be ideally perfect.
- Assumed that neighboring substations are working properly.

A. Reliability Effect on Substation Lines

To understand the reliability effect on substation lines, consider a 'S/S 1' substation as shown in Fig. 1. 'S/S 2' is the neighboring substation that comprise of circuit breakers that will be perfect, i.e. S/S 2 circuit breaker will never fail.

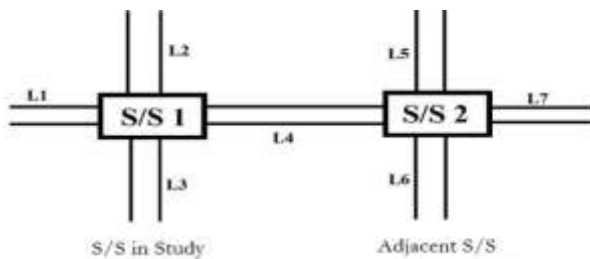

Figure 1. Reliability effect on substation lines

Lines 1, 2, 3, and 4 will be affected if "S/S 1" fails. Hence, S/S 1 reliability assessment determines lines 1, 2, 3, and 4 failure frequency (fre), mean time to repair (MTTR), unavailability (U), and mean time to failure (MTTF). By

equations (3) and (4) the above discussed reliability indices are related to each other.

$$U = \frac{\text{MTTR} \times \text{frequency}}{8760} \quad (3)$$

$$\text{frequency} = \frac{1}{\text{MTTR} + \text{MTTF}} \quad (4)$$

MTTR in equation (3) is calculated in hours, but MTTF and MTTR both in equation (4) are measured in years.

B. Reliability Data

The different components of substation i.e. voltage transformer, current transformer, CBs, and other components of switchgear, failure statistics are unavailable for power system of Pakistan. Thus, various sources are used to get the statistics from [8,9]. The substation configuration data and transmission line lengths are carried from the Pakistan's national grid operator, NTDC.

C. Reliability Evaluation of NTDC Substations

Pakistan's national grid operator i.e. NTDC operates and maintains twenty-nine 220 KV and twelve 500 KV grid stations, [10]. Reliability assessment of five 220 kV substations that are Tarbela, Burhan, Islamabad, Peshawar and Daudkhel are compared in this paper. Detail analysis for 220 kV Tarbela substation is presented.

Distance protection, differential protection,

and busbar protection in substation coordinates with each other. The fault location mainly determines which of these protection schemes respond to fault. For the components, the effect on the protection will be the similar that are within one protection zone. Hence, the 220 kV Tarbela grid substation can be divided into three zone types.

a. Zone-1: Bus Bar

As in Fig. 2, the initiating fault occurred in busbar protection zone, it should react and isolates the D3Q3, D2Q2 and D1Q2 circuit breakers. The failure function of CB will be activated and trip Burhan-1, D1Q1, Burhan-3, D2Q1, Mardan-1 and D3Q1 if any of these CBs does not respond. In substation, there is no back-up protection. If the protection of busbar fails to respond, then fault in this substation will not be sensed by the distance protection. It will be seen by the nearby substation's distance protection that will clears the fault. Therefore, it is assumed that it will shut down the whole substation.

In fig. 3 the event tree for busbar (BB2) fault zone is shown. There will be no lines isolated if both the associated CBs and busbar protection (primary protection) works effectively. The CB failure function will isolate the next stage of CBs if busbar protection successfully works, but fails to trip one of the associated CBs. In this case, the corresponding lines Burhan-1/2 and Burhan-3, Mardan-1/2 and Islamabad will be isolated. If the busbar fault fails to detect by the busbar protection it will shut down the entire substation. The condition is not considered where back-up protection and primary protection both fails, since in this study the back-up protection is supposed to be ideally perfect.

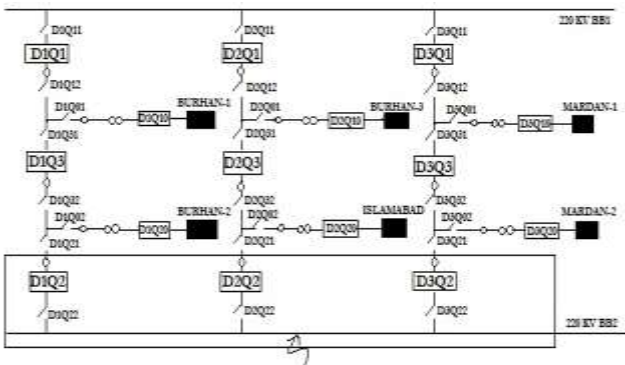

Figure 2. 220 kV Tarbela substation Busbar Zone

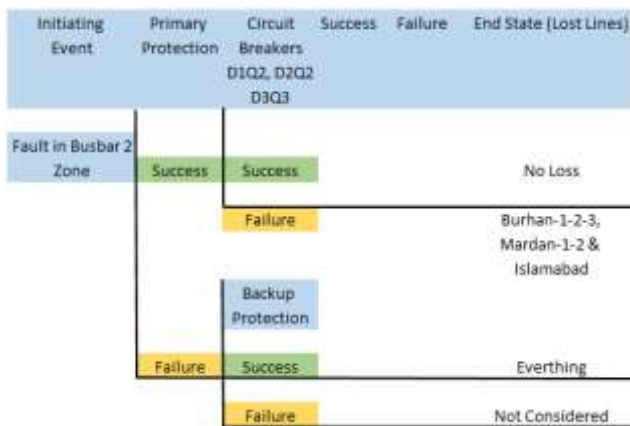

Figure 3. Tarbela S/S Event tree for Busbar 2 zone

b. Zone-2: Line

In Fig. 4, a line zone with fault occurring is shown. If the line fault occurs, firstly the field differential protection should respond. If line fault is initiating fault, then differential protection of line will react as primary protection. Since reliability study does not have any impact if protection system will isolate the same CBs for those two faults. Therefore, a single line zone is formed by combining those two zones. In fig. 5 the event tree for Islamabad line zone fault is shown. In this case, the CBs D2Q2, D2Q3 and D2Q0 will be tripped by the primary differential protection and isolates only the line Islamabad. If any of the CBs fails, the failure function of CB

will trip Burhan-3, D2Q1, D1Q2, D3Q2, and isolates the line of Islamabad. The line distance protection should response if differential protection of line fails to detect the fault and trip the CBs: D2Q3, D2Q0 and D2Q2. In this case, the line Islamabad will only be isolated.

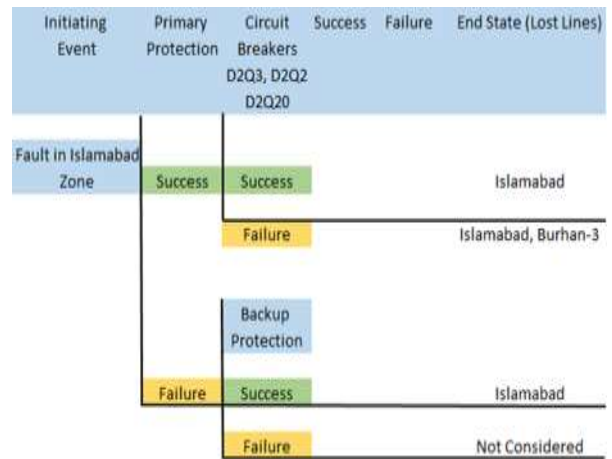

Figure 4. 220 kV Tarbela substation Line zone

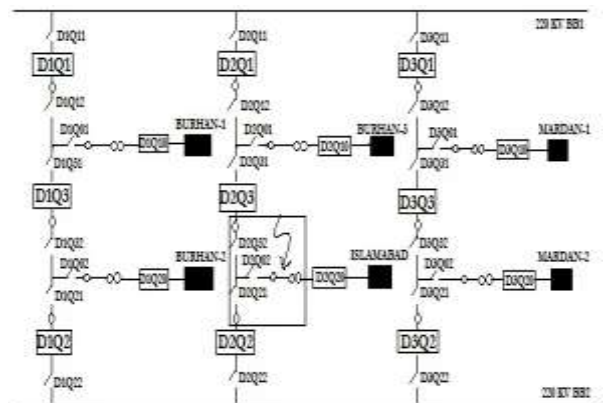

Figure 5. Tarbela S/S Event Tree Line Zone

c. Zone 3: Step-down Transformer

In fig. 6 the zone for step-down transformer is presented. In this case if fault occurs on line, then field differential of line will response first. If it is line fault, the differential protection of line will act as primary protection. If the fault is in the zone of transformer, it is cleared by the field differential protection of transformer. The similar CBs will trip by these various modes of primary protection systems, therefore, combined these three various zones into one.

In fig.7 the event tree for Burhan-2 fault zone is shown. If this zone detects an initiating fault, the CBs: D1Q2, D1Q20, D1Q3 will be trip by the primary differential protection and isolates only Burhan-2. If one of these CBs: D2Q2, D3Q2 and D1Q1 fails to respond, the circuit breaker failure function will isolate Burhan-1. It will also isolate Burhan-2. The distance protection should respond due to the failure of primary protection and it will isolate Burhan-1.

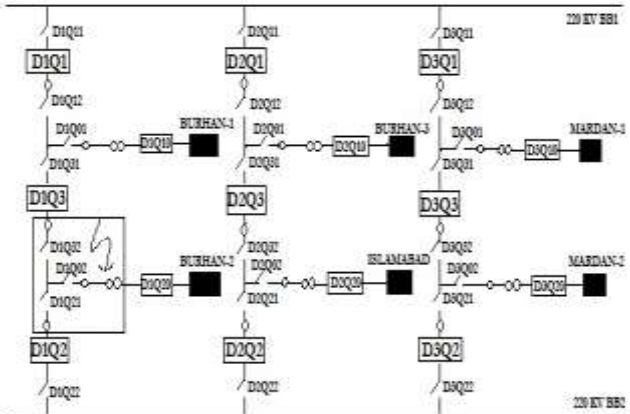

Figure 6. 220 kV Tarbela grid station Step-down transformer zone

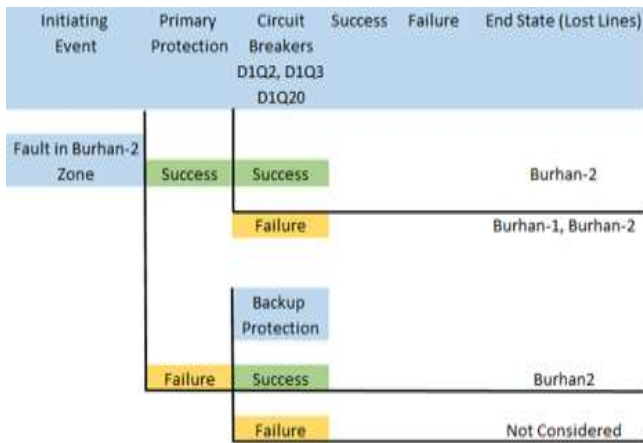

Figure 7. Step-down Transformer Event tree for fault zone

3. RESULTS & ANALYSIS

The frequency failures and resulting probabilities of lines can be calculated from event tree. By using a small fault tree, the initiating events unavailability and failure frequency is computed first. The zone is considered as failed if any of the components inside a zone fails. As such, each zone reliability can be evaluated as it is considered as a small series associated system.

TABLE I: ZONE RELIABILITY OF TARBELA S/S

In Table I the Tarbela substation zone reliability is presented.

Zone	Failure Frequency of Zone	Unavailability of Zone
Burhan1	0.08701	0.00007936
Burhan2	0.08701	0.00007936
Burhan3	0.08766	0.00008006
Islamabad	0.1472	0.00013446
Mardan1	0.1573	0.00015705
Mardan2	0.1573	0.00015705

Above calculations are the outcomes of Fault Tree Analysis and used for Event Tree Analysis input.

By applying the technique discussed in section III, the losing lines frequency and probability can be evaluated by adding up the same end states failure statistics. In Table II results are presented.

TABLE II: FAILURE STATISTICS OF SPECIFIC LINES

Substation	Zone: Most Reliable	Zone: Most Unreliable
TARBELA	Burhan1 and 2	Mardan1 and 2
ISLAMABAD	Burhan	Mansahra
PESHAWAR	Sheikh Muhammadi1 and 2	Ghazi Barotha
BURHAN	Sangjany	Tarbela3
DAUDKHEL	CHASNUPP1 and 2	Sheikh Muhammadi

Due to any fault in the components the line's frequency failure and unavailability shows the probability that this substation line is isolated. Using event trees these are calculated. In reliability assessment, it is observed that transmission lines are the dominant element. The longer the line, greater the possibility that the fault occurs in line.

The longest transmission lines are Mardan-1 and Mardan-2: 67 km. So, these are the highest failure frequency lines. The MTTF shows that due to a fault in the component it takes average time before the specific line isolated. The MTTR shows that the line takes average time to detect and clear the fault, and then placed that isolated line in return to function.

In terms of highly reliable zone, a data of the five NTDC 220 kV substations and the highest probability zone to fail on behalf of all five substations are showed in Table III. The highest reliable zone is the one which has least failure frequency or highest MTTF and the zone which have highest frequency failure or lowest MTTF has the highest possibility of failure.

TABLE III: ZONE RELIABILITY OF GRID SUBSTATION

Lost line	Unavailability	Frequency Failure (fr)	MTTF (Year)	MTTR (Hr)
Burhan1	3.90E-04	0.0865	11.47	39.22
Buhan2	3.90E-04	0.0865	11.47	39.22
Burhan3	3.93E-04	0.0871	11.39	39.09
Islamabad	6.61E-04	0.1464	6.69	38.49
Mardan1	7.06E-04	0.1563	6.33	38.51
Mardan2	7.06E-04	0.1563	6.33	38.51

Overall frequency failure, MTTF and unavailability of the five NTDC 220 kV substations are shown in figures 8(a) to 8(c).

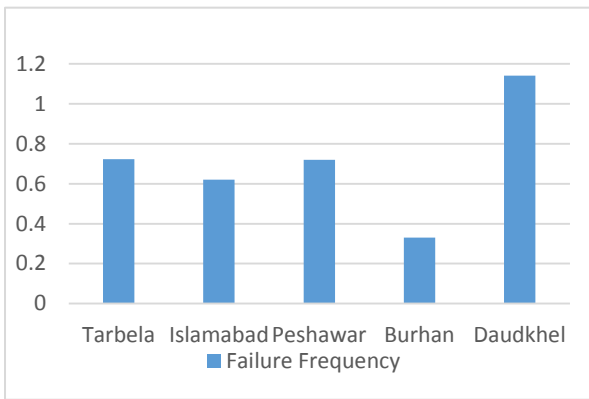

(a)

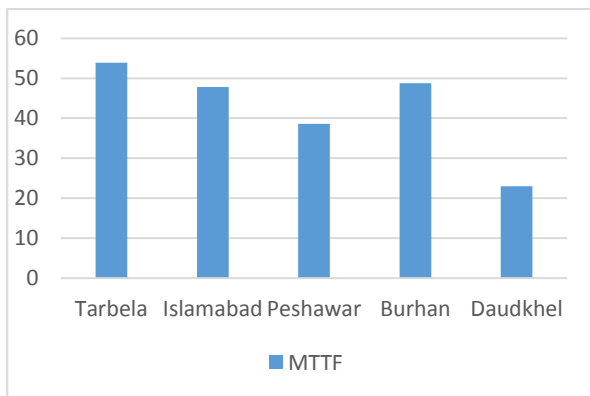

(b)

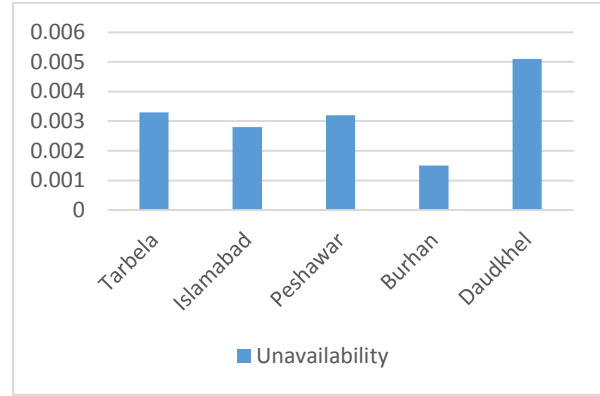

(c)

Figure 8. Reliability Tables of five 220kV substations: (a) failure frequency, (b) MTTF (c) unavailability

By adding up the different zone's failure frequency and unavailability, the overall failure frequency and unavailability is computed. Then by using Eqs. (3) & (4) MTTF is computed. From figure, the highest unavailability substation is Daudkhel which has of slightly over 0.0050, followed by an unavailability of Tarbela which is over 0.0030. Burhan and Islamabad substations have same level of unavailability as they are near the Islamabad, the capital city. Tarbela grid substation has the highest MTTF.

With lowest MTTF and highest frequency failure the Daudkhel substation is most vulnerable. Failure frequency and MTTF of Islamabad substation will seriously affect operational safety and design of the proposed new substation of 220 kV at Mansahra.

CONCLUSION

Reliability of five NTDC 220kV substations are examined and their frequency failure, unavailability and MTTF is compared in this paper. This study will help the NTDC to understand the area of grid station where most faults occur. By proper maintenance of components in substation reliability can be enhanced. During the study, it has been observed that the transformers and line/cables are the major part in the calculation of the system's reliability, due to their large failure frequency the lines with similar location and parameters will have similar statistics of failure. All the substation components are supposed to be working properly in this paper, which shows that maintenance is not included. In future studies maintenance might be included.

ACKNOWLEDGMENTS

We would to acknowledge all the faculties and students of Electrical Engineering Department, UET Peshawar for their assistance, anticipation and resources extended to us.

REFERENCES

- [1] Roy Billinton, R.A., Reliability Evaluation of Power Systems. Second Edition, 1996, New York.

- [2] Adebayo, Kehinde Hussein, Adebayo, Adeyinka Victor “A Reliability Assessment of Power Transmission And Distribution Systems; Ibadan South-West Nigeria As a Case Study” Oasis Journal of Research and Development, Vol 1 No 2, pp1-14, June 2011.
- [3] Ying-Yi Hong, Lun-Hui Lee Heng-Hsing Cheng, Reliability Assessment of Protection System for Switchyard Using Fault- Tree Analysis, International Conference on Power System Technology, 2006 IEEE.
- [4] Dong, D. O.Koval, and J. E. Propst, “Reliability of various Industrial substations,” *IEEE Trans. Ind. Appl.*, vol. 40, no. 4, pp. 989–994, Jul.2004.
- [5] M. Rausand and A. Hoyland, System Reliability Theory: Models, Statistical Methods, and Applications, 2nd ed. Hoboken, NJ: Wiley, 2004.
- [6] L. Haarla, U. Pulkkinen, M. Koskinen, and J. Jyrinsalo, “A method for analyzing the reliability of a transmission grid,” Reliability Engineering and System Safety, vol. 93, no. 2, pp. 277–287, Feb. 2008.
- [7] MEGBOWON, I.O. and Oyebisi, T. O. “A Reliability Assessment of the South-Western Transmission Lines of the Nigeria national Grid”, in International Journal of Engineering and Engineering Technology, FUTAJEET 4, (1)17 – 22, (2005).
- [8] F. Wang, “Reliability Evaluation of Substations Subject to Protection Failures,” M. Eng. thesis, Delft University of Technology, Delft, the Netherlands, July 2012.
- [9] Mohammad Sadegh Javadi, Azim Nobakht, Ali Meskarbashee, Fault Tree Analysis Approach in Reliability Assessment of Power System, International Journal of Multidisciplinary Sciences and Engineering, Vol. 2, No. 6, September 2011.
- [10] NTDC website. [Online]. Available: <http://www.ntdc.com.pk/Grid500.php>



Engr. Muhammad Adeel Khan is a post-graduate research scholar in Department of Electrical Engineering, University of Engineering and Technology Peshawar, Pakistan. He received his BS degree from COMSATS Institute of Information Technology Abbottabad in 2012. His research area includes Power system reliability and power system protection.

adeel_khan18a@yahoo.com 0092-3347354535

Muhammad Iftikhar Khan is associate professor in Department of Electrical Engineering, University of Engineering and Technology Peshawar, Pakistan. Miftikhar74@gmail.com

Mubasher Hussain is a post-graduate research scholar in Department of Electrical Engineering, University of Engineering and Technology Peshawar, Pakistan. He received his BS degree from COMSATS Institute of Information Technology Abbottabad in 2012. His research area includes operation of power system and transformers. mubasherhussain921@yahoo.com